

Chain according to ISO 606		Pitch	Inner width	Inner link width	Outer plate width	Roller Ø	Pin Ø	Plate height	Projection over connecting link	Width over pin	Bearing area	Breaking load	Weight	Connecting links
⚙️		p	b ₁ min.	b ₂ max.	b ₃ min.	d ₁ max.	d ₂ max.	g max.	k max.	l ₁ max.	f	F _B min.	q ≈	No.
No.	Ind.	mm	mm	mm	mm	mm	mm	mm	mm	mm	cm ²	kN	kg/m	No.
450 RF	^{10,11}	8,000	3,00	4,77	4,90	5,00	2,31	7,1	3,1	8,6	0,11	4,0	0,18	4,7,11
331 RF	^{10,11}	12,700	3,30	5,80	5,93	7,75	3,66	9,9	1,5	10,2	0,21	7,0	0,28	4,7,11,15
332 RF	^{10,11}	12,700	4,88	7,20	7,33	7,75	3,66	9,9	1,5	11,2	0,28	7,0	0,33	4,7,11,15
462 RF	⁷	12,700	7,75	11,30	11,43	8,51	4,45	11,8	3,9	17,0	0,50	12,0	0,70	4,7,11,12,15
501 RF		15,875	9,65	13,28	13,41	10,16	5,08	14,7	4,1	19,6	0,67	14,5	0,91	4,7,11,12,15
513 RF		19,050	11,68	15,62	15,75	12,07	5,72	16,1	4,6	22,7	0,89	18,5	1,18	4,7,11,12,15
548 RF	¹¹	25,400	17,02	25,40	25,60	15,88	8,28	21,0	5,4	36,1	2,10	40,0	2,50	4,7,11,12
35 RF	^{2,11}	9,525	4,68	7,47	7,52	5,08	3,58	9,1	3,3	13,2	0,27	6,0	0,35	4,7,11
40 RF	^{10,11}	12,700	7,85	11,15	11,28	7,95	3,96	12,0	3,9	17,8	0,44	10,5	0,61	4,7,11,12,15
60 RF	¹¹	19,050	12,57	17,70	17,85	11,91	5,94	18,0	4,6	26,9	1,05	20,0	1,58	4,7,11,12
455 RFGL	^{10,11}	9,525	5,72	8,53	8,66	6,35	3,28	8,2	3,3	13,5	0,28	7,0	0,41	4,7,11,12,15
455 RFKIGL	^{2,7}	9,525	5,72	8,53	8,66	6,35	3,28	8,2	3,3	13,5	0,28	1,0	0,25	4,7,11
462 RFKI	^{2,7}	12,700	7,75	11,30	11,43	8,51	4,45	11,5	3,9	17,0	0,50	12,0	0,44	4,7,11
462 RFGL	²	12,700	7,75	11,30	11,43	8,51	4,45	11,5	3,9	17,0	0,50	12,0	0,78	4,7,11,12,15
501 RFGL		15,875	9,65	13,28	13,41	10,16	5,08	14,2	4,1	19,6	0,67	14,5	1,03	4,7,11,12,15
513 RFGL		19,050	11,68	15,62	15,75	12,07	5,72	15,5	4,6	22,7	0,89	18,5	1,29	4,7,11,12,15
548 RFGL	¹¹	25,400	17,02	25,40	25,60	15,88	8,28	24,0	5,4	36,1	2,10	40,0	3,29	4,7,11,12
548 RFGLS	¹¹	25,400	17,02	25,40	25,60	15,88	8,28	21,0	5,4	36,1	2,10	40,0	2,90	4,7,11,12

² without rollers (DIN 8154) ⁷ inner links made entirely of plastic, maintenance-free chain ¹⁰ connecting link No. 12 only with attached riveted bolts
¹¹ sprockets on request

Roller chains RF (stainless steel) - type series GL (straight plates) can also be supplied as multiplex roller chains. For details on orders and enquiries see page 131. For sprockets RF (stainless steel) see page 86.

Connecting links: According to ISO (...)



No. 4 (B)

No. 7 (A)

No. 11 (E)

No. 111 (S)

No. 12 (L)

No. 15 (C)

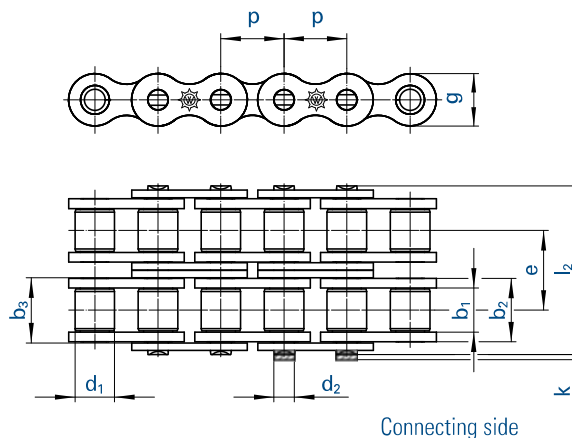

Chain according to ISO 606		Pitch	Inner width	Inner link width	Outer plate width	Roller Ø	Pin Ø	Transverse pitch	Plate height	Projection over connecting link	Width over pin	Bearing area	Breaking load	Weight	Connecting links
⚙️		p	b ₁ min.	b ₂ max.	b ₃ min.	d ₁ max.	d ₂ max.	e	g max.	k max.	l ₂ max.	f	F _B min.	q ≈	No.
No.	Ind.	mm	mm	mm	mm	mm	mm	mm	mm	mm	mm	cm ²	kN	kg/m	No.
D450 RF		8,000	3,00	4,77	4,90	5,00	2,31	5,64	7,1	3,1	14,3	0,22	6,00	0,36	4,7,11,15
D455 RF	¹	9,525	5,72	8,53	8,66	6,35	3,28	10,24	8,2	3,3	23,8	0,56	11,90	0,78	4,7,11,15
D462 RF		12,700	7,75	11,30	11,43	8,51	4,45	13,92	11,8	3,9	31,0	1,01	20,40	1,36	4,7,11,12,15
D501 RF		15,875	9,65	13,28	13,41	10,16	5,08	16,59	14,7	4,1	36,2	1,34	24,65	1,82	4,7,11,12,15
D513 RF		19,050	11,68	15,62	15,75	12,07	5,72	19,46	16,1	4,6	42,2	1,79	31,45	2,38	4,7,11,12,15
D548 RF		25,400	17,02	25,40	25,60	15,88	8,28	31,88	21,0	5,4	68,0	4,21	68,00	5,10	4,7,11,12
35-2 RF		9,525	4,68	7,47	7,52	5,08	3,58	10,13	9,0	3,3	23,4	0,53	12,00	0,70	11,12,15
40-2 RF		12,700	7,85	11,15	11,28	7,95	3,96	14,38	12,0	3,9	32,3	0,88	17,85	1,20	11,12,15
60-2 RF		19,050	12,57	17,70	17,85	11,91	5,94	22,78	18,0	4,6	49,8	2,10	34,00	3,14	4,7,11,12

¹ with straight side plates

For details on orders and enquiries see page 131. Sprockets on request.

Connecting links: According to ISO (...)



No. 4 (B)



No. 7 (A)



No. 11 (E)



No. 111 (S)



No. 12 (L)



No. 15 (C)

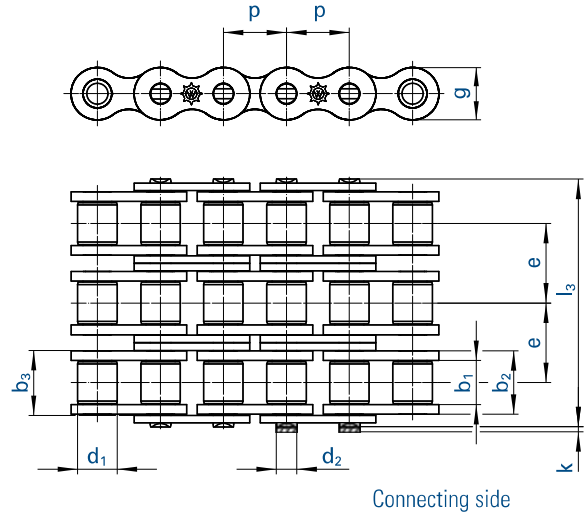

Chain according to ISO 606		Pitch		Inner width	Inner link width	Outer plate width	Roller Ø	Pin Ø	Transverse pitch	Plate height	Projection over connecting link	Width over pin	Bearing area	Breaking load	Weight	Connecting links
No.		p		b ₁ min.	b ₂ max.	b ₃ min.	d ₁ max.	d ₂ max.	e	g max.	k max.	l ₃ max.	f	F _B min.	q ≈	No.
No.	Ind.	mm	inch	mm	mm	mm	mm	mm	mm	mm	mm	mm	cm ²	kN	kg/m	No.
T 455 RF	¹	9,525	3/8	5,72	8,53	8,66	6,35	3,28	10,24	8,2	3,3	34,0	0,81	18,9	1,18	11,12,15
T 462 RF		12,700	1/2	7,75	11,30	11,43	8,51	4,45	13,92	11,8	3,9	44,9	1,51	32,5	2,01	11,12,15
T 501 RF		15,875	5/8	9,65	13,28	13,41	10,16	5,08	16,59	14,7	4,1	52,8	2,02	39,0	2,70	11,12,15
T 513 RF		19,050	3/4	11,68	15,62	15,75	12,07	5,72	19,46	16,1	4,6	61,7	2,68	49,5	3,12	11,12,15
T 548 RF		25,400	1	17,02	25,40	25,60	15,88	8,28	31,88	21,0	5,4	99,9	6,31	108,0	7,50	111,12

¹ with straight side plates

For details on orders and enquiries see page 131, Sprockets on request.
Information on the selection of chain sizes and drives as of page 118.

Connecting links: According to ISO (...)



No. 4 (B)

No. 7 (A)

No. 11 (E)

No. 111 (S)

No. 12 (L)

No. 15 (C)